



800mA Lithium Ion Battery Linear Charger KF5404D

General Description

KF5404D is a complete constant-current/constant voltage linear charger for single cell lithium-ion batteries. Furthermore the KF5404D is specifically designed to work within USB power specifications.

No external sense resistor is needed and no blocking diode is required due to the internal PMOSFET architecture. Thermal feedback regulates the charge current to limit the die temperature during high power operation or high ambient temperature. The charge voltage is fixed at 4.34V, and the charge current can be programmed externally with a single resistor. The KF5404D automatically terminates the charge cycle when the charge current drops to 1/10th the programmed value after the final float voltage is reached.

When the input supply (wall adapter or USB supply) is removed the KF5404D automatically enters a low current state dropping the battery drain current to less than 2 μ A. The KF5404D can be put into shutdown mode reducing the supply current to 55 μ A.

Other features include charge current monitor, undervoltage lockout, automatic recharge and a status.

Features

- Protection of battery cell reverse connection
- No MOSFET sense resistor or blocking diode required
- Complete Linear Charger in ThinSOT Package for Single Cell Lithium-Ion Batteries
- Constant-Current/Constant-Voltage operation with thermal regulation to maximize Rate Without risk of overheating.
- Preset 4.34V charge voltage with $\pm 1\%$ accuracy
- Automatic Recharge
- Charges Single Cell Li-Ion Batteries Directly from USB Port
- C/10 charge termination
- 55 μ A supply current in shutdown
- 2.9V trickle current charge threshold
- Soft-Start limits inrush current
- Charge Status Output Pin
- Available in SOT-23-5 Package

Applications

- Cellular Telephones, PDAs, MP3 Players
- Charging Docks and Cradles
- Bluetooth Applications

Typical Application

600mA Single Cell Li-Ion Charger

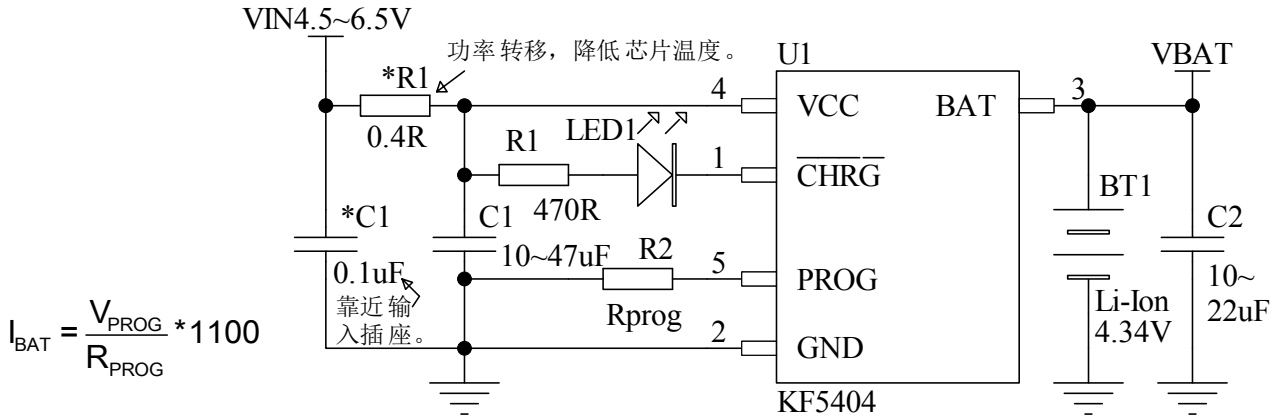

Typical charge cycle (750mAh batter)

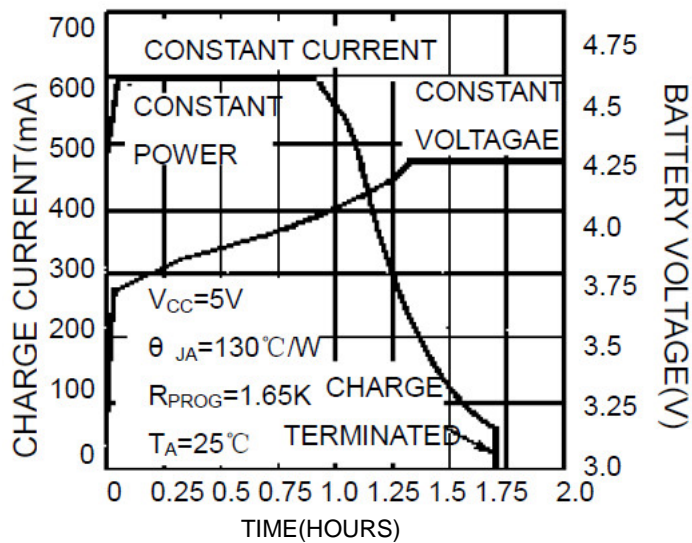

Selection Guide

KF 5404D X X G

- Environment mark
- Package:
M5-SOT-23-5
- Function: The Thermal protection temperature is 110 °C and the float voltage is 4.34V
- Product Type
- Product Series
- Product labeling

Pin Configuration

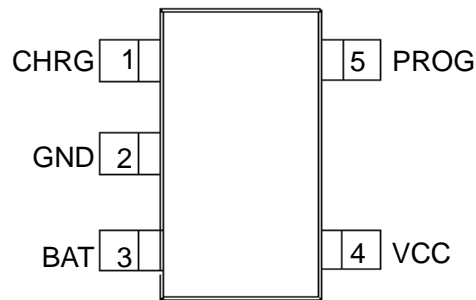

SOT-23-5

Pin Assignment

KF5404DM5G

Pin Num.	Symbol	Function
1	CHRG	Open-Drain charge status output When the battery is being charged, the $\overline{\text{CHRG}}$ pin is pulled low by an internal switch, otherwise, $\overline{\text{CHRG}}$ pin is in high impedance state.
2	GND	Ground
3	BAT	Battery connection Pin Connect the positive terminal of the battery to this pin. Dropping BAT pin's current to less than 2 μ A when IC in disable mode or in sleep mode. BAT pin provides charge current to the battery and provides regulation voltage of 4.34V.
4	VCC	Positive input supply voltage Provides power to the internal circuit. When V_{CC} drops to within 80mV of the BAT pin voltage, the KF5404D enters low power sleep mode, dropping I_{BAT} to less than 2 μ A.
5	PROG	Constant Charge Current Setting and Charge Current Monitor Pin The charge current is programmed by connecting a resistor R_{PROG} from this pin to GND. When in precharge mode, the PROG pin's voltage is regulated to 0.1V. When charging in constant-current mode this pin's voltage is regulated to 1V. In all modes during charging, the voltage on this pin can be used to measure the charge current using the following formula: $I_{\text{BAT}} = \frac{V_{\text{PROG}}}{R_{\text{PROG}}} * 1100$



Block Diagram

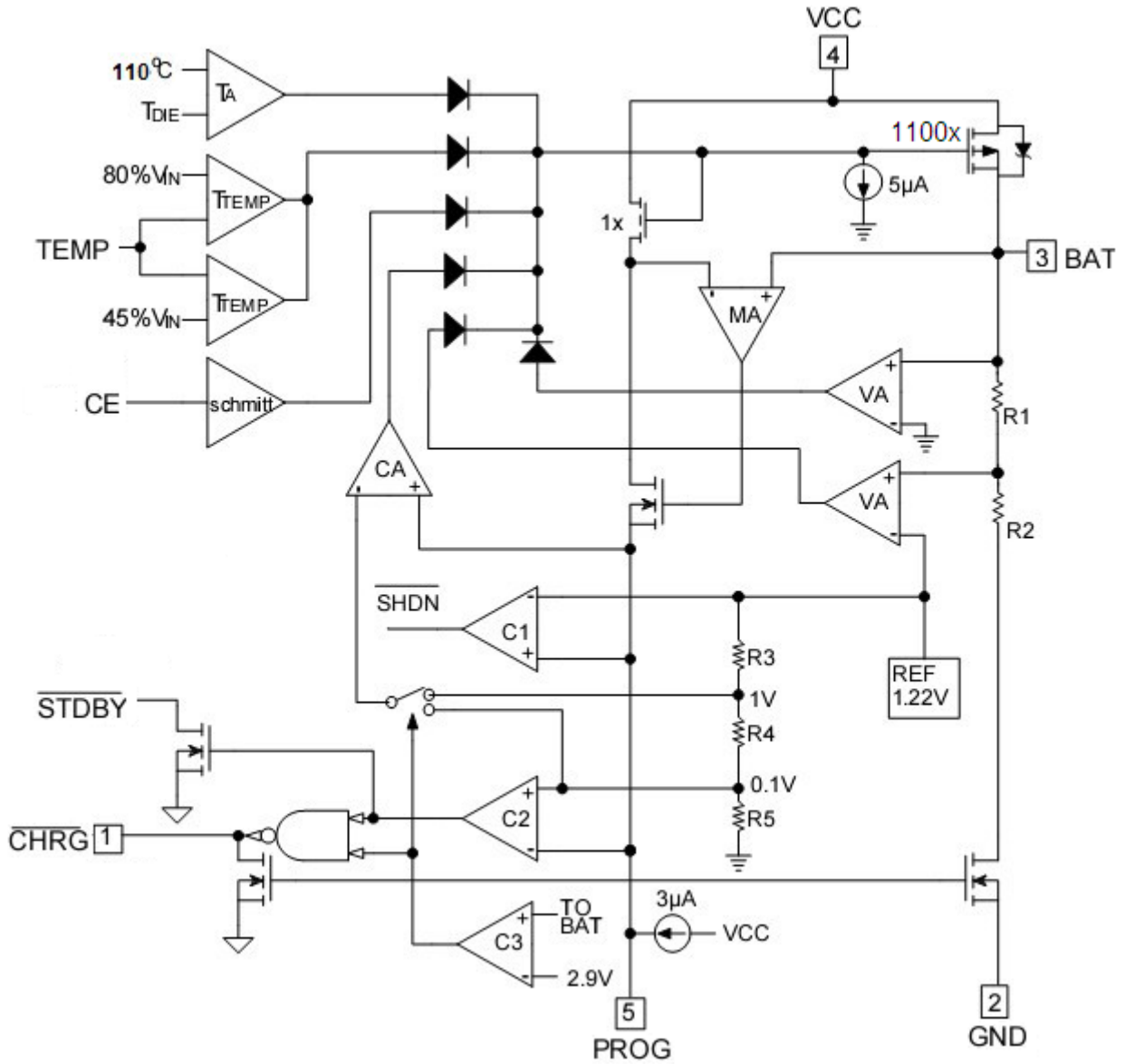

**Absolute Maximum Ratings**

Parameter	Rating	Unit
Input supply voltage : V_{CC}	-0.3~6.5	V
PROG pin voltage	-0.3~ $V_{CC}+0.3$	V
BAT pin voltage	-0.3~6.5	V
\overline{CHRG} pin voltage	-0.3~6.5	V
BAT pin current	800	mA
PROG pin current	1200	μ A
Maximum junction temperature	145	$^{\circ}$ C
Operating ambient temperature : T_{opa}	-40~85	$^{\circ}$ C
Storage temperature : T_{str}	-65~125	$^{\circ}$ C
Soldering temperature and time	+260 (Recommended 10S)	$^{\circ}$ C

Caution: The absolute maximum ratings are rated values exceeding which the product could suffer physical damage. These values must therefore not be exceeded under any conditions.



Electrical Characteristics

Symbol	Parameter	Condition	Min	Typ.	Max	Unit
V _{CC}	Input supply voltage	•	4.0	5.0	6.5	V
I _{CC} -I _{BAT}	static current	<ul style="list-style-type: none"> • Charge mode, R_{PROG}=1.1KΩ • Standby mode(charge end) • Shutdown mode (R_{PROG} not connected, V_{CC}<V_{BAT}, or V_{CC}<V_{UV}) 	-	150	500	μA
V _{FLOAL}	Regulated output voltage	0°C≤T _A ≤85°C	4.3	4.34	4.38	V
I _{BAT}	BAT pin current (The condition of current mode is V _{BAT} =3.9V)	<ul style="list-style-type: none"> • R_{PROG}=2.2KΩ, current mode • R_{PROG}=1.1KΩ, current mode • Standby mode: V_{BAT}=4.34V • Shutdown mode, R_{PROG} not connected • Sleep mode, V_{CC}=0V 	450	500	550	mA
I _{TRIKL}	Trickle charge current	• V _{BAT} <V _{TRIKL} , R _{PROG} =1.1KΩ	120	130	140	mA
V _{TRIKL}	Trickle charge threshold voltage	R _{PROG} =1.1KΩ, V _{BAT} rising	2.8	2.9	3.0	V
V _{TRHYS}	Trickle voltage hysteresis voltage	R _{PROG} =1.1KΩ	150	200	250	mV
V _{UV}	V _{CC} under voltage lockout threshold	• V _{CC} from low to high	3.5	3.7	3.9	V
V _{UVHYS}	V _{CC} under voltage lockout hysteresis	•	150	200	300	mV
V _{ASD}	V _{CC} -V _{BAT} lockout threshold voltage	V _{CC} from low to high	100	140	180	mV
		V _{CC} from high to low	50	80	110	
I _{TERM}	termination current threshold	<ul style="list-style-type: none"> • R_{PROG}=2.2KΩ • R_{PROG}=1.1KΩ 	60	70	80	mA
			120	130	140	
V _{PROG}	PROG pin voltage	• R _{PROG} =1.1KΩ, current mode	0.9	1.0	1.1	V
V _{CHRG}	<u>CHRG</u> Pin output low voltage	I _{CHRG} =5mA	-	0.3	0.6	V
ΔV _{RECHRG}	Recharge battery threshold voltage	V _{FLOAT} -V _{RECHRG}	120	180	240	mV
T _{LIM}	Thermal protection temperature		-	110	-	°C
R _{ON}	The resistance of power FET "ON" (between V _{CC} and BAT)		-	650	-	mΩ
t _{SS}	Soft-start time	I _{BAT} =0 to I _{BAT} =1100V/R _{PROG}	-	20	-	μS
t _{RECHARGE}	Recharge comparator filter time	V _{BAT} from high to low	0.8	1.8	4	mS
t _{TERM}	Termination comparator filter time	I _{BAT} below I _{CHG} /10	0.8	1.8	4	mS
I _{PROG}	PROG pin pull-up current		-	2.0	-	μA

Note: The • denotes specifications which apply over the full operating temperature rang, otherwise specifications are at T_A=25°C, V_{CC}=5V, unless otherwise specified.



Typical performance characteristics

V_{FLOAT} VS VCC

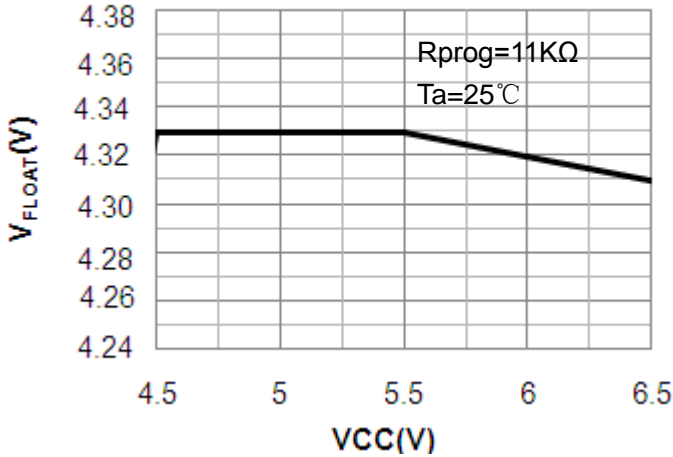

V_{FLOAT} VS Temperature

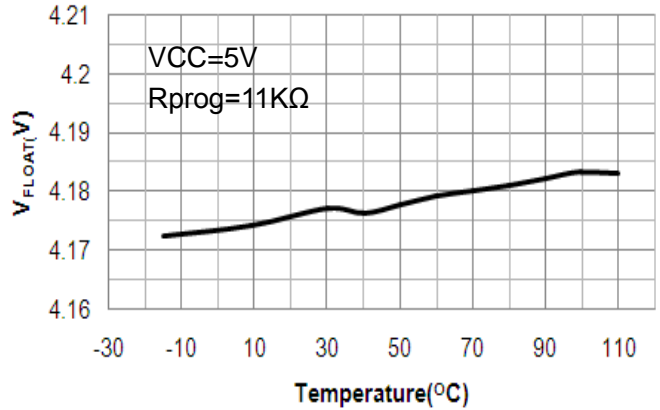

Current mode, PROG Pin VS VCC

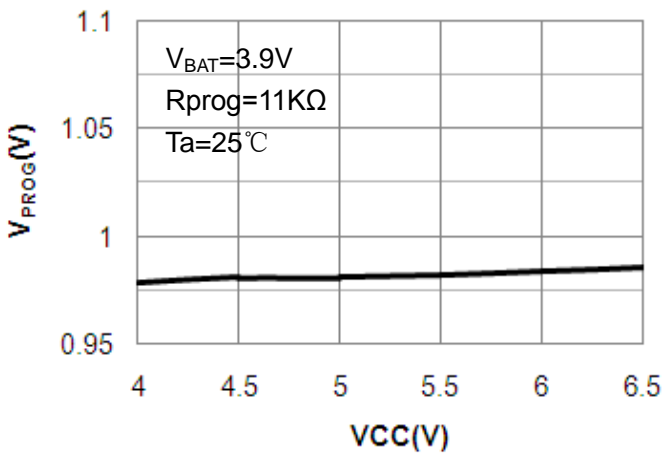

PROG Pin Voltage VS Temperature

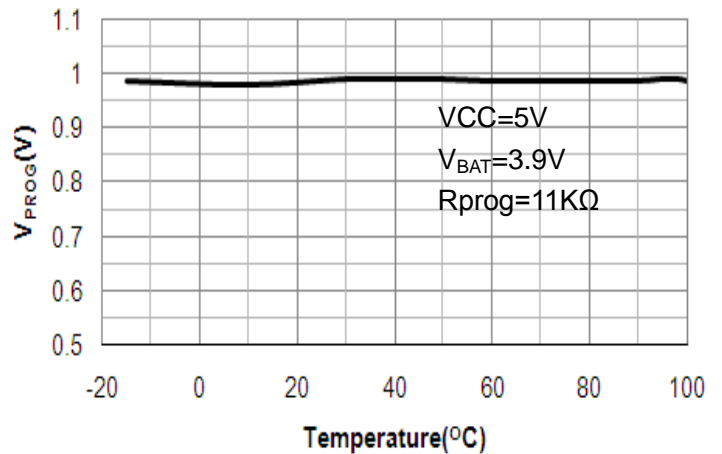

Description of the Principle

The KF5404D is a complete constant-current/constant-voltage linear charger for single cell lithium-ion batteries. Constant-current/constant-voltage to charger batter by internal MOSFET .It can deliver up to 800mA of charge current .No blocking diode or external current sense resistor is required. KF5404D include one Open-Drain charge status Pin: Charge status indicator **CHRG**

The internal thermal regulation circuit reduces the programmed charge current if the die temperature attempts to rise above a preset value of approximately 110°C. This feature protects the KF5404D from excessive temperature, and allows the user to push the limits of the power handling capability of a given circuit board without risk of damaging the KF5404D or the external components. Another benefit of adopting thermal regulation is that charge current can be set according to typical, not worst-case, ambient temperatures for a given application with the assurance that the charger will automatically reduce the current in worst-case conditions.

The charge cycle begins when the voltage at the V_{CC} pin rises above the UVLO level, a current set resistor is connected from the PROG pin to ground. The \overline{CHRG} pin outputs a logic low to indicate that the charge cycle is on going. At the beginning of the charge cycle, if the battery voltage is below 2.9V, the charge is in precharge mode to bring the cell voltage up to a safe level for charging. The charger goes into the fast charge constant-current mode once the voltage on the BAT pin rises above 2.9 V. In constant current mode, the charge current is set by R_{PROG} . When the battery approaches the regulation voltage 4.34V, the charge current begins to decrease as the KF5404D enters the constant-voltage mode. When the current drops to charge termination threshold, the charge cycle is terminated, and \overline{CHRG} pin assumes a high impedance state to indicate that the charge cycle is terminated . The charge termination threshold is 10% of the current in constant current mode. To restart the charge cycle, remove the input voltage and reapply it . The charge cycle can also be automatically restarted if the BAT pin voltage falls below the recharge threshold. The on-chip reference voltage, error amplifier and the resistor divider provide regulation voltage with 1% accuracy which can meet the requirement of lithium-ion and lithium polymer batteries. When the input voltage is not present, or input voltage is below V_{BAT} , the charger goes into a sleep mode, dropping battery drain current to less than 3 μ A. This greatly reduces the current drain on the battery and increases the standby time. The charging profile is shown in the following figure:

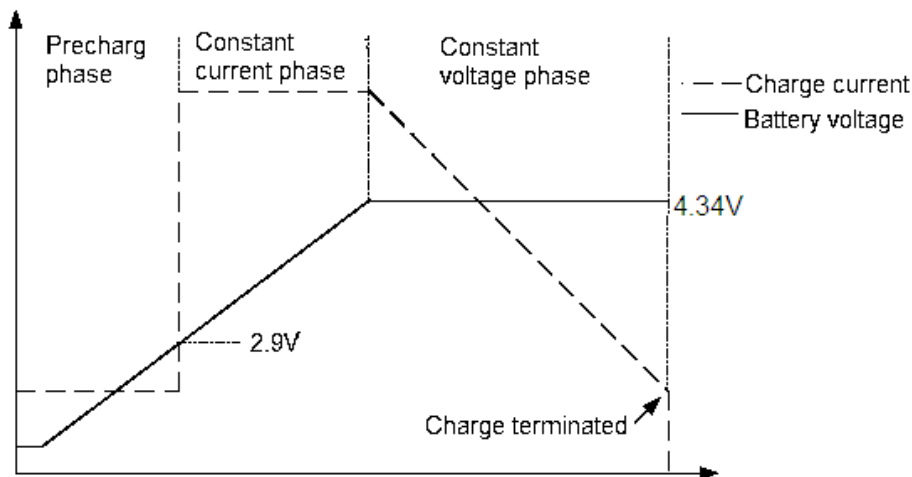

Programming charge current

The charge current is programmed using a single resistor from the PROG pin to ground. The program resistor and the charge current are calculated using the following equations.:

$$R_{PROG} = \frac{1100}{I_{BAT}} (\text{error } \pm 10\%)$$

In application, according the charge current to determine R_{PROG} , the relation between R_{PROG} and charge current can reference the following chart:



$K = \frac{1100}{R_{PROG} \times I_{BAT}}$	I_{BAT} (mA)	R_{PROG} (K Ω)
0.9	30	40
0.75	60	24
0.8	114	12
0.9	305	4
1	650	1.7
1.1	1000	1

Note:

- K is the coefficient of variation, It generally is 1, but due to the vary operating environment, K is varied in the range: 0.8~1.4
- The up form is just for reference, it will varied $\pm 10\%$ according to the heat dissipation of the using PCB board;
- The footprint copper pads should be as wide as possible and expand out to larger copper areas to spread and dissipate the heat to the surrounding ambient.

Charge termination

A charge cycle is terminated when the charge current falls to 1/10th the programmed value after the final float voltage is reached. This condition is detected by using an internal filtered comparator to monitor the PROG pin. When the PROG pin voltage falls below 100mV for longer than t_{TEMP} (typically 1.8mS), Charging is terminated. The charge current is latched off and the KF5404D enters standby mode, where the input supply current drops to 55 μ A (Note:C/10 termination is disabled in trickle charging and thermal limiting modes).

When charging, transient loads on the BAT pin can cause the PROG pin to fall below 100mV for short periods of time before the DC charge current has dropped to 1/10th the programmed value. The 1.8mS filter time (t_{TEMP}) on the termination comparator ensures that transient loads of this nature do not result in premature charge cycle termination. Once the average charge current drops below 1/10th the programmed value, the KF5404D terminated the charge cycle and ceases to provide any current through the BAT pin. In this state all loads on the BAT pin must be supplied by the battery.

The KF5404D constantly monitors the BAT pin voltage in standby mode. If this voltage drops below the 4.16V recharge threshold (V_{RECHRG}), another charge cycle begins and current is once again supplied to the battery. To manually restart a charge cycle when in standby mode, the input voltage must be removed and reapplied or the charger must be shut down and restarted using the PROG pin. Figure 1 shows the state diagram of a typical charge cycle.

Charge Status Indicator (CHRG)

KF5404D has one open-drain status indicator output \overline{CHRG} . \overline{CHRG} is pull-down when the KF5404D in a charge cycle. In other status \overline{CHRG} in high impedance.

Represent in failure state, when the charger with no battery: LED don't light. If battery is not connected to charger, \overline{CHRG} pin outputs a PWM level to indicate no battery. If BAT pin connects a 10 μ F capacitor, the frequency of \overline{CHRG} flicker about 1-4S, If not use status indicator should set status indicator output connected to GND.



Thermal limiting

An internal thermal feedback loop reduces the programmed charge current if the die temperature attempts to rise above a preset value of approximately 110°C . The feature protects the KF5404D from excessive temperature and allows the user to push the limits of the power handling capability of a given circuit board without risk of damaging the KF5404D. The charge current can be set according to typical (not worst-case) ambient temperature with the assurance that the charger will automatically reduce the current in worst-case conditions.

Under Voltage lockout (UVLO)

An internal under voltage lockout circuit monitors the input voltage and keeps the charger in shutdown mode until VCC rises above the under voltage lockout threshold . If the UVLO comparator is tripped, the charger will not come out of shutdown mode until VCC rises 140mV above the battery voltage.

Manual terminate

At any time of the cycle of charging will put the KF5404D into disable mode to remove R_{PROG} (PROG pin is float) . This made the battery drain current to less than 2μA and reducing the supply current to 55μA. To restart the charge cycle, connect a programming resistor.

If KF5404D in the under voltage Lockout mode, the $\overline{\text{CHRG}}$ is in high impedance state, or VCC is above BAT pin 140mV, or V_{CC} is too low.

Auto restart

Once charge is been terminated, KF5404D immediately use a 1.8ms filter time (t_{RECHARGE}) on the termination comparator to constant monitor the voltage on BAT pin. If this voltage drops below the 4.16V recharge threshold (about between 80% and 90% of V_{CC}), another charge cycle begins. This ensured the battery maintained (or approach) to a charge full status and avoid the requirement of restarting the periodic charging cycle. In the recharge cycle, $\overline{\text{CHRG}}$ pin enters a pulled down status.

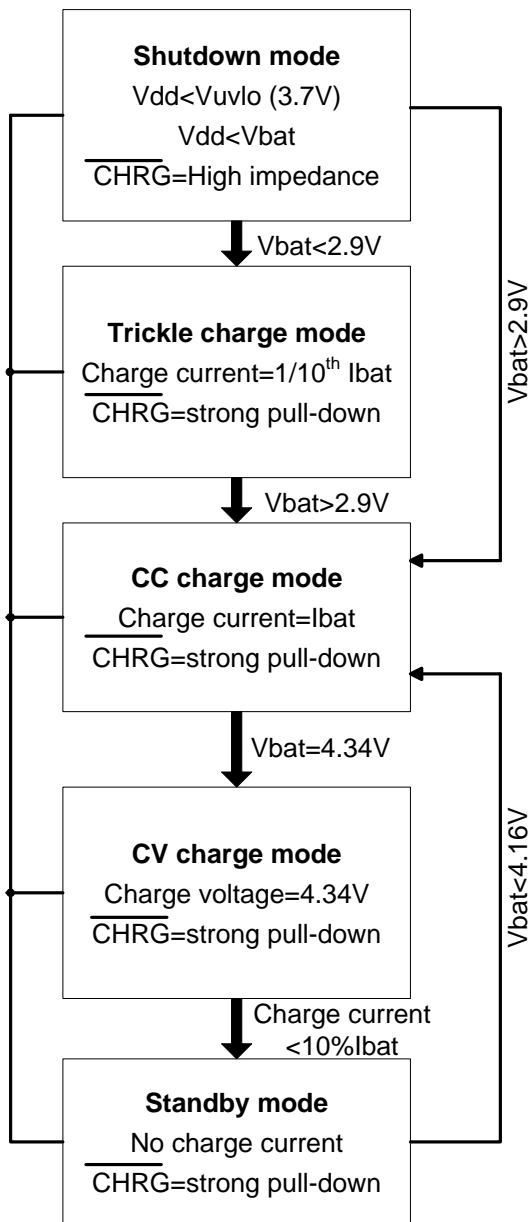

Fig.1 State diagram of a typical charge cycle

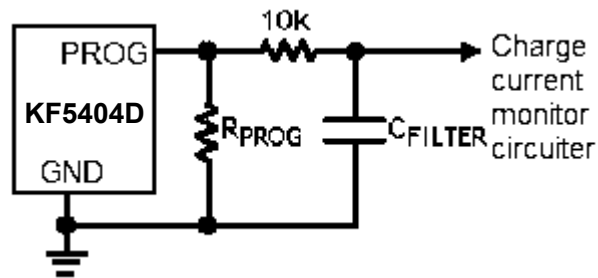

Fig.2 Isolating with capacitive load on PROG Pin

Stability Considerations

In constant-current mode, the PROG pin is in the feedback loop, not the battery. The constant-current mode stability is affected by the impedance at the PROG pin. With no additional capacitance on the PROG pin, the charger is stable with program resistor values as high as 20KΩ. However, additional capacitance on this node reduces the maximum allowed program resistor. Therefore, if I_{PROG} pin is loaded with a capacitance C, the following equation should be used to calculate the maximum resistance value for R_{PROG}:

$$R_{PROG} \leq \frac{1}{2\pi \cdot 10^5 \cdot C_{PROG}}$$

As user, may think charge current is important, not instantaneous current. For example, to run a low current mode switch power which parallel connected with battery, the average current from BAT pin usually importance to instantaneous current. In this case, In order to measure average charge current or isolate capacitive load from I_{PROG} pin, a simple RC filter can be used on PROG pin as shown in Figure 2. In order to ensure the stability add a 10KΩ resistor between PROG pin and filter capacitor.



Power dissipation

The conditions that cause the KF5404D to reduce charge current through thermal feedback can be approximated by considering the power dissipated in the IC. Nearly all of this power dissipation is generated by the internal MOSFET-this is calculated to be approximately: $P_D = (V_{CC} - V_{BAT}) \times I_{BAT}$

The approximate ambient temperature at which the thermal feedback begins to protect the IC is:

$$T_A = 110^\circ C - P_D \theta_{JA}; \quad T_A = 110^\circ C - (V_{CC} - V_{BAT}) \times I_{BAT} \times \theta_{JA}$$

For example: The KF5404D with 5V supply voltage through programmable provides full limiting current 800mA to a charge lithium-ion battery with 3.75V voltage. If θ_{JA} is $150^\circ C/W$ (reference to PCB layout considerations), When KF5404D begins to decrease the charge current, the ambient temperature about:

$$T_A = 110^\circ C - (5V - 3.75V) \times (800mA) \times 150^\circ C/W$$

$$T_A = 110^\circ C - 0.5W \times 150^\circ C/W = 110^\circ C - 75^\circ C \quad T_A = 35^\circ C$$

KF5404D can work in the condition of the temperature is above $35^\circ C$, but the charge current will pull down to below 800mA. In a fixed ambient temperature, the charge current is calculated to be approximately :

$$I_{BAT} = \frac{110^\circ C - T_A}{(V_{CC} - V_{BAT}) \times \theta_{JA}}$$

Just as Description of the Principle part talks about so, the current on PROG pin will reduce in proportion to the reduced charge current through thermal feedback. In KF5404D design applications don't need to considerate the worst case of thermal condition, this point is importance, because if the junction temperature up to $110^\circ C$, IC will auto reduce the power dissipation.

Thermal considerations

Because of the small size of the thin SOT-23-5 package, it is important to use a good thermal PC board layout to maximize the available charge current. The thermal path for the heat generated by the IC is from the die to the copper lead frame, through the package leads, (especially the ground lead) to the PC board copper. The PC board copper is the heat sink. The footprint copper pads should be as wide as possible and expand out to larger copper areas to spread and dissipate the heat to the surrounding ambient. Other heat sources on the board, not related to the charger, must also be considered when designing a PC board layout because they will affect overall temperature rise and the maximum charge current.

Add thermal regulation current

It will effective to decrease the power dissipation through reduce the voltage of both ends of the inner MOSFET. In the thermal regulation, this action of transporting current to battery will raise. One of the measure is through an external component(as a resistor or diode) to consume some power dissipation.

For example: The KF5404D with 5V supply voltage through programmable provides full limiting current 800mA to a charge lithium-ion battery with 3.75V voltage. If θ_{JA} is $105^\circ C/W$, so that at $25^\circ C$ ambient temperature, the charge

current is calculated to be approximately :

$$I_{BAT} = \frac{110^\circ C - 25^\circ C}{(V_S - I_{BAT} \times R_{CC} - V_{BAT}) \times \theta_{JA}}$$

In order to increase the thermal regulation charge current, can decrease the power dissipation of the IC through reducing the voltage (as show fig.3) of both two ends of the resistor which connecting in series with a 5V AC adapter.

With square equation to calculate I_{BAT} :

$$I_{BAT} = \frac{(V_S - V_{BAT}) - \sqrt{(V_S - V_{BAT})^2 - \frac{4R_{CC}(110^\circ C - T_A)}{\theta_{JA}}}}{2R_{CC}}$$

If $R_{CC}=0.25\Omega$, $V_S=5V$, $V_{BAT}=3.75V$, $T_A=25^\circ C$ and $\theta_{JA}=105^\circ C/W$, we can calculate the thermal regulation charge current: $I_{BAT}=764mA$. It means that in this structure it can output 800mA full limiting charge current at more high ambient temperature environment.

Although it can transport more energy and reduce the charge time in this application, but actually spread charge time, if KF5404D stay in under-voltage state, when V_{CC} becomes too low in voltage mode. Fig.4 shows how the voltage reduced with increase R_{CC} value in this circuit. This technique will act the best function when in order to maintain the minimize the dimension of the components and avoid voltage decreased to minimize R_{CC} .

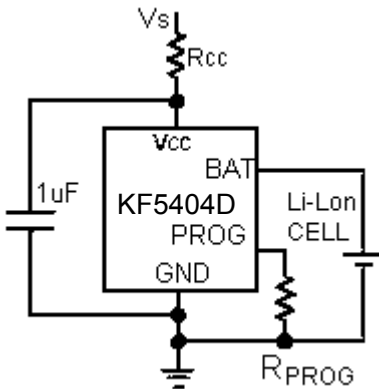

Fig.3:A circuit to maximum the thermal regulation charge current

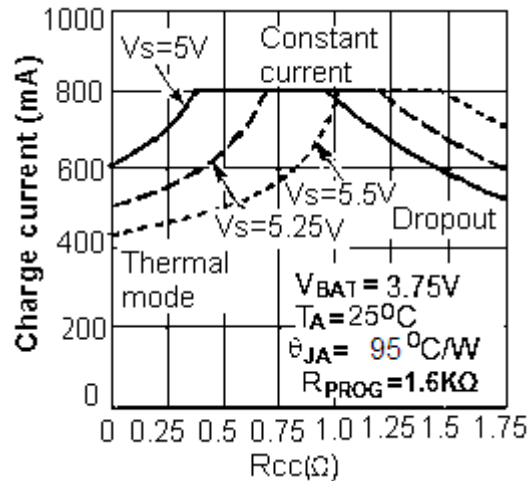

Fig.4:The relationship curve between charge current with R_{CC}

V_{CC} bypass capacitor

Many types of capacitors can be used for input bypassing, however, caution must be exercised when using multilayer ceramic capacitors. Because of the self-resonant and high Q characteristics of some types of ceramic capacitors, high voltage transients can be generated under some start-up conditions, such as connecting the charger input to a live power source. Adding a 1.5Ω resistor in series with a ceramic capacitor will minimize start-up voltage transients.

Charging Current Soft Start

KF5404D includes a soft start circuit which used to maximize to reduce the surge current in the begging of charge cycle. When restart a new charge cycle, the charging current ramps up from 0 to the full charging current within $20\mu s$. In the start process it can maximize to reduce the action which caused by surge current load.

USB and Wall Adapter Power

KF5404D allows charging from a USB port, a wall adapter can also be used to charge Li-Ion/Li-polymer batteries. Figure 5 shows an example of how to combine wall adapter and USB power inputs. A P-channel MOSFET, M1, is used to prevent back conducting into the USB port when a wall adapter is present and Schottky diode, D1, is used to prevent USB power loss through the $1K\Omega$ pull-down resistor.

Generally, AC adaptor is able to provide bigger much current than the value of specific current limiting which is 500mA for USB port. So can rise charge current to 600mA with using a N-MOSFET (MN1) and an additional set resistor value as high as $10K\Omega$.

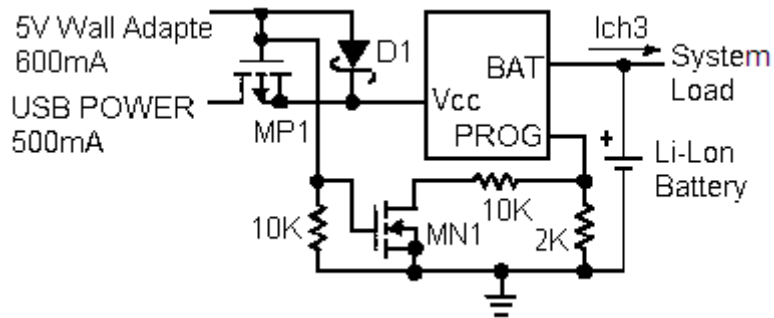
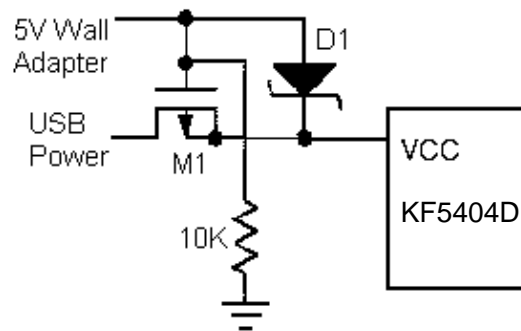

Fig.5:Combining Wall Adapter and USB Power

Typical Application

Mainly used in Cellular telephones, MP3, MP4 players, digital still cameras, electronic dictionary, GPS, portable devices and vary chargers.

1. Suitable for the application of USB power and the charge of wall adapter



2. Add a resistor for power dissipation

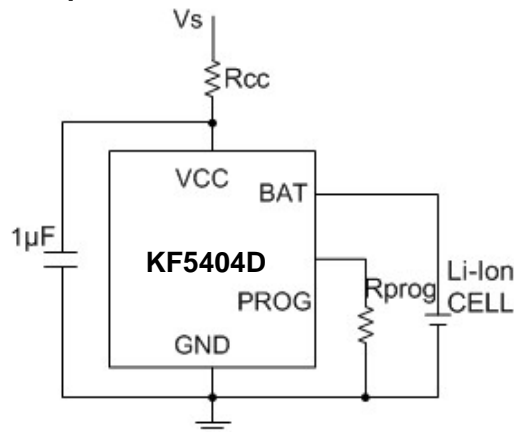



Board Layout Considerations

- R_{PROG} at PROG pin should be as close to KF5404D as possible, also the parasitic capacitance at PROG pin should be kept as small as possible.
- The capacitance at V_{CC} pin and BAT pin should be as close to KF5404D as possible.
- It is very important to use a good thermal PC board layout to maximize charging current. The thermal path for the heat generated by the IC is from the die to the copper lead frame through the package lead (especially the ground lead) to the PC board copper, the PC board copper is the heat sink. The footprint copper pads should be as wide as possible and expand out to larger copper areas to spread and dissipate the heat to the surrounding ambient. Feed through vias to inner or backside copper layers are also useful in improving the overall thermal performance of the charger. Other heat sources on the board, not related to the charger, must also be considered when designing a PC board layout because they will affect overall temperature rise and the maximum charge current.
- The ability to deliver maximum charge current under all conditions require that the exposed metal pad on the back side of the KF5404D package be soldered to the PC board ground. Failure to make the thermal contact between the exposed pad on the backside of the package and the copper board will result in larger thermal resistance.



Packaging Information:

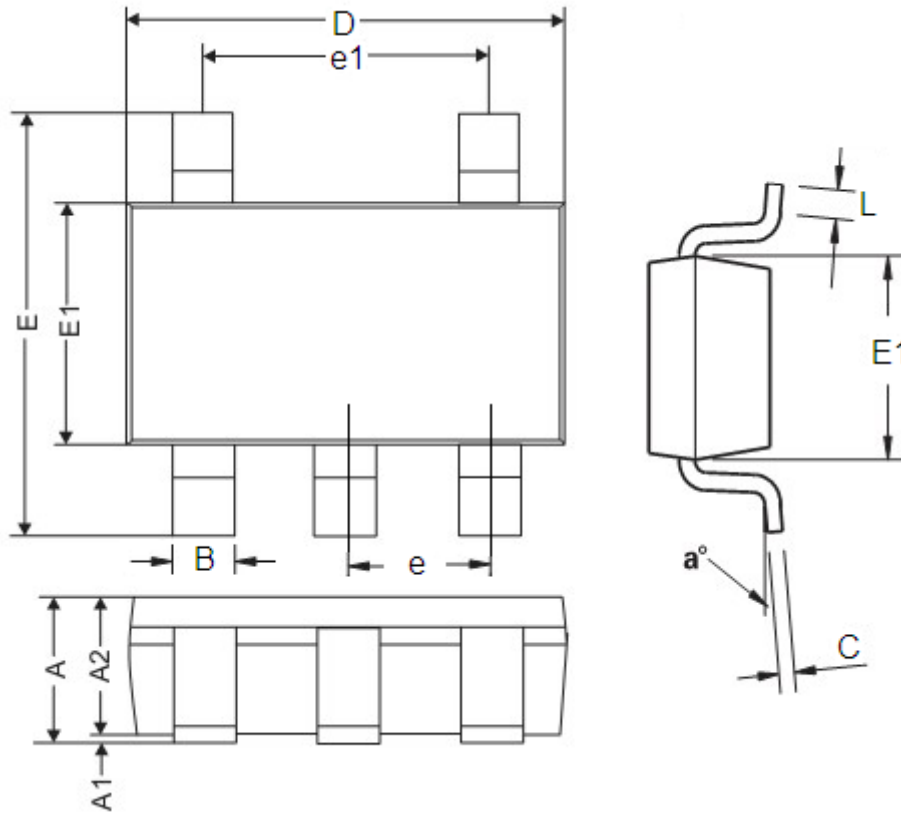

Package type:SOT-23-5 Unit:mm(inch)

DIM	Millimeters		Inches	
	Min	Max	Min	Max
A	0.9	1.45	0.0354	0.0570
A1	0	0.15	0	0.0059
A2	0.9	1.3	0.0354	0.0511
B	0.2	0.5	0.0078	0.0196
C	0.09	0.26	0.0035	0.0102
D	2.7	3.10	0.1062	0.1220
E	2.2	3.2	0.0866	0.1181
E1	1.30	1.80	0.0511	0.0708
e	0.95REF		0.0374REF	
e1	1.90REF		0.0748REF	
L	0.10	0.60	0.0039	0.0236
a°	0°	30°	0°	30°



- 本资料内容如有更改，恕不另行通知。
- 深圳市科发鑫电子有限公司是不负责造成的本文所述电路或图表的任何问题，其相关的工业产权，专利或其他权利属于第三方。另外，应用电路示例解释产品的典型应用，并不能保证任何具体的大规模生产设计的成功。
- 严禁利用本文所述用于其他目的和/或无深圳市科发鑫电子有限公司的明确许可，转载或复制的信息。
- 本文描述的产品不能使用任何装置或设备对人体产生影响，如健身器材，医疗器械，安全系统，燃气设备，或安装在飞机和其他车辆的任何设备，无需深圳市科发鑫电子有限公司的事先书面许可。
- 虽然深圳市科发鑫电子有限公司发挥最大可能的努力，以确保高品质和可靠性，半导体产品的故障或故障可能发生。因此，这些产品的用户应该对安全性的设计给予充分考虑，包括冗余，防火措施和故障预防，防止任何意外，火灾，社会性损害可能发生。

- The information described herein is subject to change without notice.
- ShenZhen Xin Kefa Electronics Co., Ltd. is not responsible for any problems caused by circuits or diagrams described herein whose related industrial properties, patents, or other rights belong to third parties. The application circuit examples explain typical applications of the products, and do not guarantee the success of any specific mass-production design.
- Use of the information described herein for other purposes and/or reproduction or copying without the express permission of ShenZhen Xin Kefa Electronics Co., Ltd. is strictly prohibited.
- The products described herein cannot be used as part of any device or equipment affecting the human body, such as exercise equipment, medical equipment, security systems, gas equipment, or any apparatus installed in airplanes and other vehicles, without prior written permission of ShenZhen Xin Kefa Electronics Co., Ltd..
- Although ShenZhen Xin Kefa Electronics Co., Ltd. exerts the greatest possible effort to ensure high quality and reliability, the failure or malfunction of semiconductor products may occur. The user of these products should therefore give thorough consideration to safety design, including redundancy, fire-prevention measures, and malfunction prevention, to prevent any accidents, fires, or community damage that may ensue.